

DOOR TRIGGER DIODE ISOLATION ON 99-UP WINDSTARS

- ▶ If there is a courtesy light under the driver dash, use the diagram below to interface the door trigger to an alarm system.

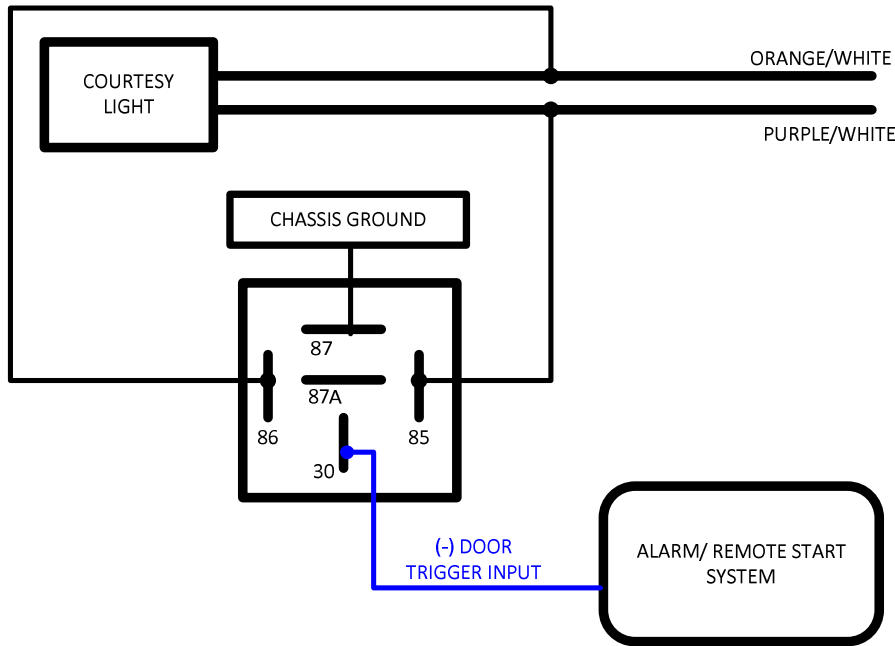

PIN	CONNECTION
85	TO PURPLE/WHITE WIRE AT COURTESY LIGHT
86	TO ORANGE/WHITE WIRE AT COURTESY LIGHT
87	TO CHASSIS GROUND
87A	NO CONNECTION
30	TO (-) DOOR TRIGGER INPUT ON ALARM SYSTEM

For Windstars without Courtesy Light Under Dash:

- ▶ On some trim levels, it is not possible to make a direct connection of the door trigger wire to the domelight.
- ▶ If the vehicle does not have a courtesy light under the dash, door trigger wires for each of the doors must be located and connected to the alarm. The door trigger wires for the front two doors and the hood trigger wire are located at the Front Electronic Module under the driver's dash against the firewall. The Rear Electronic Module is located in the passenger rear quarter panel. Find all wires and follow the diagram on the following page as shown. Diodes must be used to block the change of polarity in the modules and to prevent the door triggers from being detected by each other.

WIRE	WIRE COLOR
HOOD TRIGGER WIRE	PURPLE/ORANGE
LEFT FRONT DOOR TRIGGER WIRE	LT.GREEN/BLACK
RIGHT FRONT DOOR TRIGGER WIRE	YELLOW/LT.GREEN
LEFT REAR DOOR TRIGGER WIRE	WHITE/PURPLE
RIGHT REAR DOOR TRIGGER WIRE	DK.BLUE/LT.GREEN



NOTE:

The rear hatch wires are normally closed. To interface, a Closed Loop Adapter (part # 502T) must be used or a pin switch must be added.

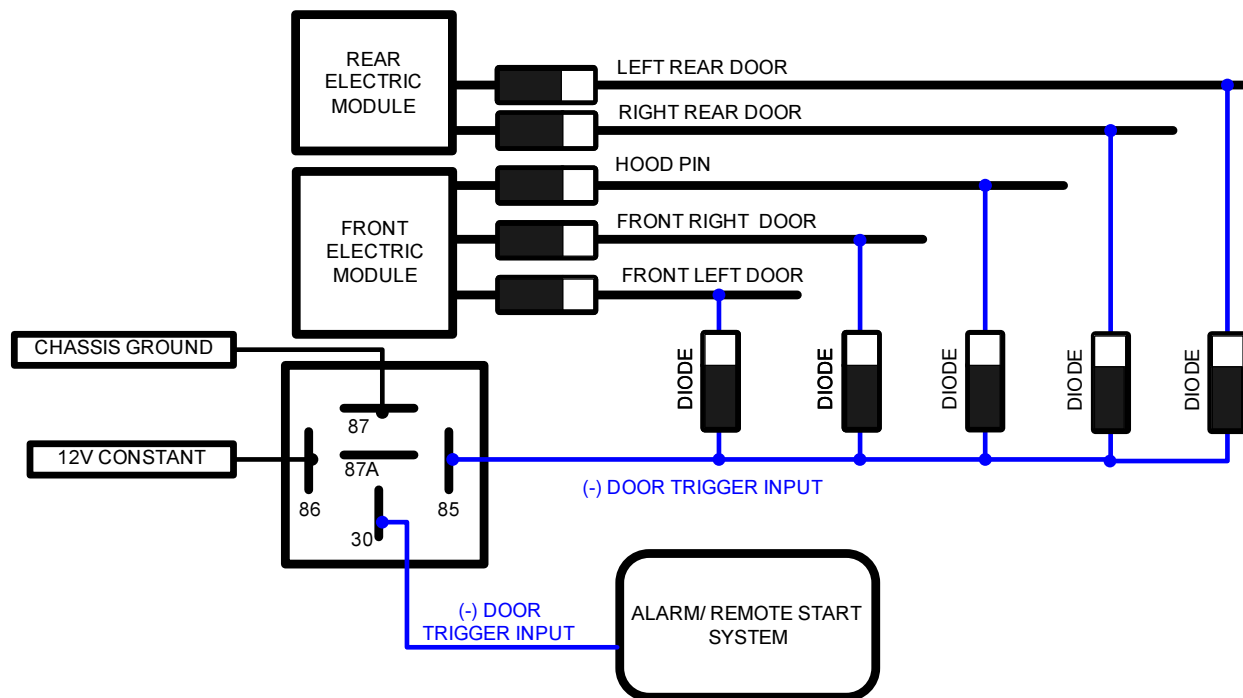

PIN	CONNECTION
85	TO INDIVIDUAL DOOR TRIGGER WIRES THROUGH DIODES
86	12V CONSTANT
87	TO CHASSIS GROUND
87A	NO CONNECTION
30	TO (-) DOOR TRIGGER INPUT ON ALARM SYSTEM

Remote starter and security installations should be attempted by experienced security installers only. Information contained is accurate to the best of our knowledge and experience. Information contained is without any representation of warranty. It is the installer's responsibility to test and confirm all circuits with a digital multi-meter. Proper installation remains the responsibility of the installer. CarInstallExperts.com assumes no liability or responsibility resulting from an improper installation, even in reliance with the information contained in this guide.